

C10 Wireless Fast Charge Vehicle Bracket

Instruction manual

Parameters Description

Product name: Wireless fast charging vehicle support (intelligent induction type)

Power: 15W/10W/7.5W

Effective transmission distance: 0-5mm

Boundary dimension: 111mm x 70mm x 46mm

Device size: 111mm x 60mm x 7.6mm

Charging Interface: TYPE-C / USB

Functional components

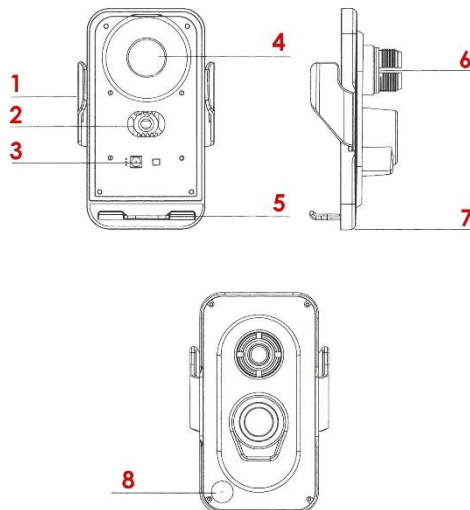

1. Automatic retractable clip
2. Mechanical equipment
3. Intelligent sensitive area
4. Wireless charging induction area
5. Bottom support
6. Ball joint
7. Type C / USB charging interface
8. Sensitive touch switch

Specifications

1. Weight: 112g
2. Material: ABS /PC + glass panel + plastic
3. Input voltage / current: 5V/2A, 9V/1.67A
4. Output power: 15W/10W/7.5W (automatic identification)
5. Rated frequency: 110k-205khz
6. Charging distance: 0 - 5mm
7. Equipment supporting QC wireless fast charging, such as:

HUAWEI: P40 / P40 Pro / Mate 30 / Mate 20 / Mate RS /

iPhone: 14 / 14Pro / 14ProMax / 13 / 13Pro / 13 Pro Max / 12 / 12Pro / 12 Pro Max / 11 / 11Pro / 11Pro / 11ProMax / X / XSMAX / XR / iPhone8 / 8P / 8Plus /

Samsung Galaxy: Note 20 / Note 10+ / Note10+5G / Note9 / Note8 / Note8 / S20 / S10+ / S10 / S9+ / S9 / S8+ and other compatible.

Wireless charger

Instructions for use:

1. Connect the product to the appropriate data cable during use.
2. Connect the USB end of the data cable to the vehicle interface (e.g., cigarette lighter converter or USB charging interface).
3. The base clamp is attached to the air outlet of the air conditioner, but can also be placed in other locations where it can be attached.
4. After the equipment is connected to the 5 - 9V DC power supply, it will automatically check the voltage, the indicator light will turn on.
5. When the cell phone is between 5cm - 20cm close to the equipment, automatically the sensor will detect you and open the arms, place the cell phone, and the device will automatically close the clamps, at that time, the wireless fast charging will be automatically activated on the cell phone (please note that the cell phone must have wireless charging function available).
6. When taking out the cell phone, you have to touch the bottom right corner of the back, finger detection area, when the finger touches this position, the device will open automatically. The device has built-in over-voltage protection, very high temperature protection, magnetic field protection and short-circuit protection. In case of abnormality, it will automatically stop working.

Precautions

1. Do not overtighten the equipment and do not strike it.
2. Do not use at high temperature. This product may prevent damage to the equipment circuit.

Thank you for using this product!